

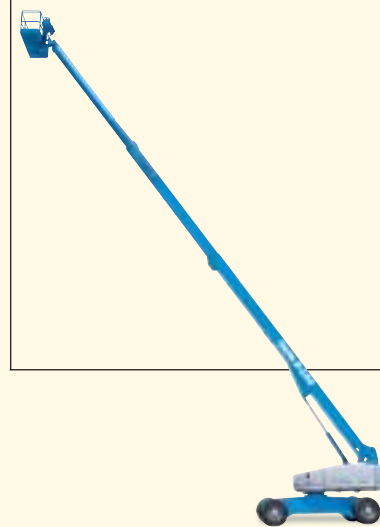

Self-Propelled Telescopic Boom

S-100/105

Four-wheel drive
and outstanding
manoeuvrability
get the tough
jobs done.



Genie Industries

S-100/105

S-100

- 32.5 m (106 ft) working height
- Industry-leading outreach of 22.9 m (75 ft)
- 340 kg (750 lb) lift capacity

S-105

- 34 m (111 ft) working height
- Industry-leading outreach of 24.4 m (80 ft)
- 227 kg (500 lb) lift capacity on the S-105

Standard Features

- Four-wheel drive with four-wheel brakes
- Extendable axles, operated from platform
- Three diesel engine options
- 2.44 m (8 ft) steel platform
- Fully proportional platform controls with ramp up/down feature
- Hydraulic platform rotation
- 360° continuous turntable rotation
- 12V DC auxiliary power
- Closed-loop hydrostatic drive
- Positive traction drive
- Drive enable system
- Self-leveling platform
- Onboard full diagnostics
- Anti-restart engine protection
- Auto engine fault shutdown
- Hydraulic oil cooler
- Engine monitoring display
- AC wiring to platform
- Foam-filled tyres
- Alarm package

Options and Accessories

- Cold start packages
- 3500 watt AC generator
- Platform swing gate
- Air line to platform
- Weld lead to platform
- Platform rail pinch guard
- Platform work lights
- Hostile environment packages
- Diesel scrubber muffler
- Platform control box cover
- Tool tray
- Driving lights

Standards Compliance

- CE EN280

Range of Motion
S-100

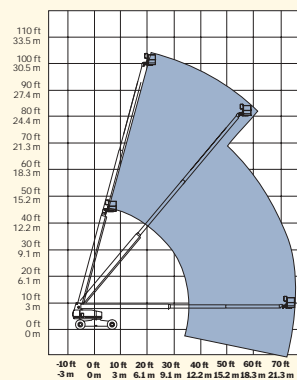

S-105

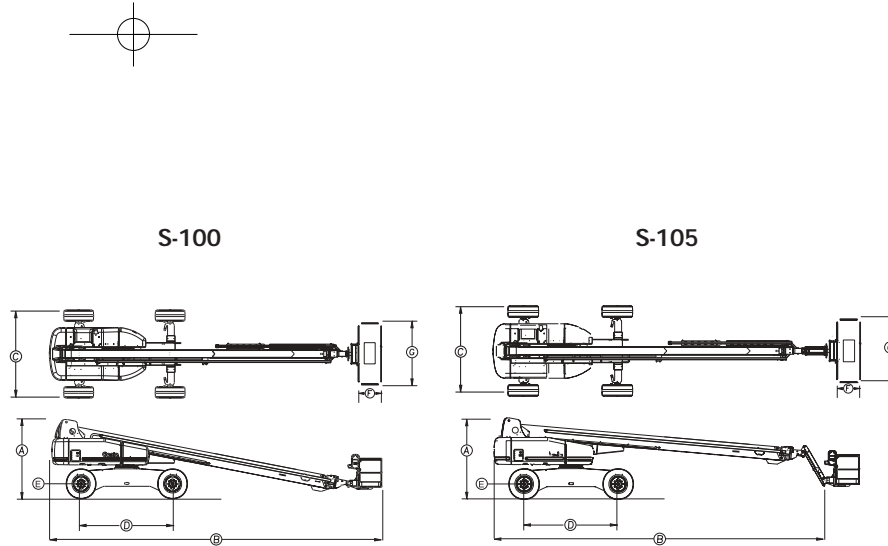
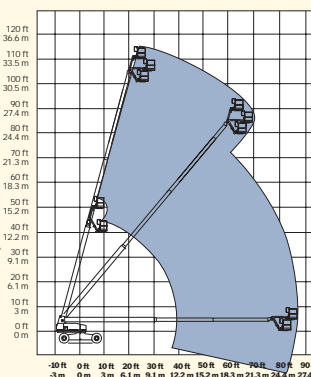

Specifications

Model	S-100		S-105	
	Metric	US	Metric	US
Working height*	32.5 m	106 ft	34 m	111 ft
Platform height	30.5 m	100 ft	32 m	105 ft
(A) Height – stowed	3.07 m	10 ft 1 in	3.07 m	10 ft 1 in
(B) Length – stowed	13 m	42 ft 8 in	14 m	46 ft
Length – transport (jib tucked underneath)	12.17 m	39 ft 11 in	12.17 m	39 ft 11 in
Width – retracted axles	2.49 m	8 ft 2 in	2.49 m	8 ft 2 in
(C) Width – extended axles	3.35 m	11 ft	3.35 m	11 ft
(D) Wheelbase	3.66 m	12 ft	3.66 m	12 ft
(E) Ground clearance	39 cm	15 ½ in	39 cm	15 ½ in
(F) Platform length	91 cm	36 in	91 cm	36 in
(G) Platform width	2.44 m	96 in	2.44 m	96 in
Horizontal reach max	22.9 m	75 ft	24.4 m	80 ft
Lift capacity	340 kg	750 lb	227 kg	500 lb
Turning radius – outside extended axles, 2-wheel steer	7.26 m	23 ft 10 in	7.26 m	23 ft 10 in
Turning radius – inside extended axles, 2-wheel steer	4.27 m	14 ft	4.27 m	14 ft
Turntable rotation	360° continuous		360° continuous	
Turntable tailswing retracted axles	1.68 m	5 ft 6 in	1.68 m	5 ft 6 in
Turntable tailswing extended axles	1.22 m	48 in	1.22 m	48 in
Power source	Cummins 4B3.9 diesel 75 hp (56 kw) Deutz F4L 913 diesel 77 hp (57 kw) Perkins 1004-42 diesel 81 hp (60 kw)			
Controls	proportional		proportional	
Platform rotation	160° hydraulic		160° hydraulic	
Auxiliary power unit	12V DC		12V DC	
Tyres	15 x 22.5, 18 pr, FF			
Hydraulic tank capacity	208 litre	55 gal	208 litre	55 gal
Fuel tank capacity	151 litre	40 gal	151 litre	40 gal
Drive speed, stowed	4.8 km/h	3 mph	4.8 km/h	3 mph
Gradeability, stowed	42%		42%	
Weight**	18,008 kg	39,700 lb	18,144 kg	40,000 lb

* The metric equivalent of working height adds 2 m to platform height. U.S. adds 6 ft to platform height
** Weight will vary depending on options and/or country standards.

Distributed By:

Genie Industries

GENIE UNITED KINGDOM

The Mallings, Wharf Road
Grantham
Lincolnshire NG31 6BH
England
Telephone: +44 (0)1476 584333
Fax: +44 (0)1476 584334
<http://www.genieindustries.com>

GENIE UNITED STATES

18340 NE 76th Street
P.O. Box 97030
Redmond, Washington 98073-9730
Telephone (425) 881-1800
Fax: +1 (425) 883-3475
<http://www.genieindustries.com>